

Two Piece Heavy Duty Silt Trap Inlet C

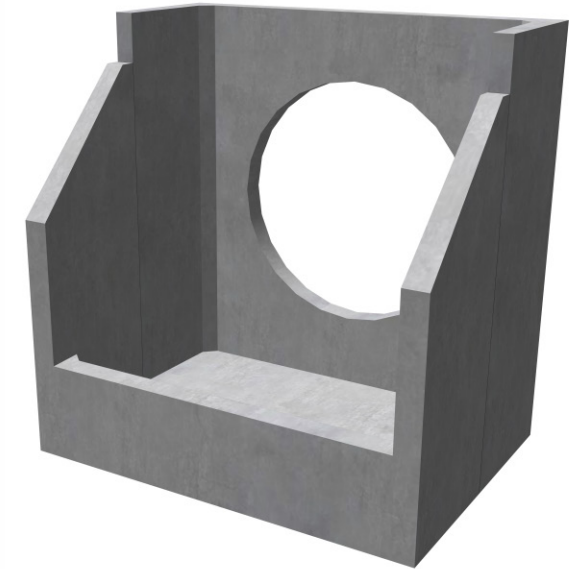
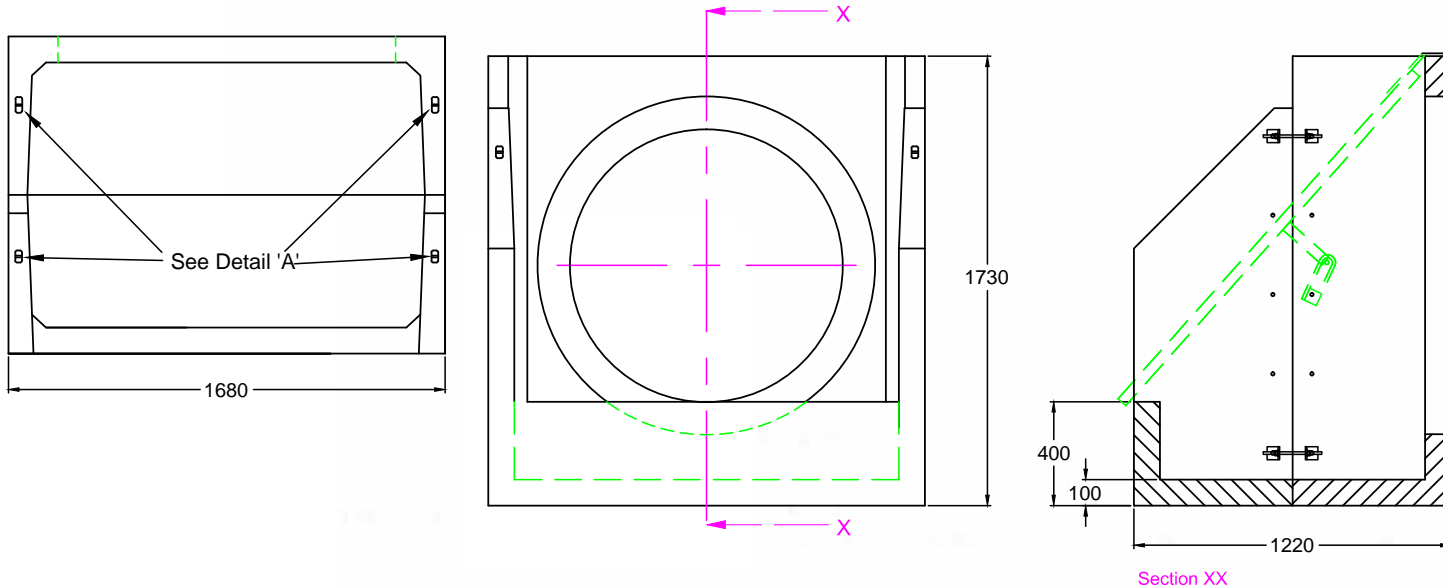

Precast Concrete Silt Traps	Max Pipe Opening (I.D) Plastic / C'ware	Max Pipe Opening (I.D) PCC	A mm	B mm	Approx Weight (KG)
2PHDSTC	1050	1050	1675	1220	1770

Headwall Details

Althon 2 Piece Heavy duty silt Traps are sturdy structures for use on large diameter pipes and are ideally suited for use in water courses with high velocities of water flow. Althon provide as standard with each unit a galvanized weed screen and removable centre panel for access to the silt for cleaning. Lifting points are cast into the wingwalls for safe handling with Althon Lifting Clutches.

Installation Instructions

1. Dig out the bank of the watercourse to take the appropriate size of the headwall making sure that the headwall will not protrude into the path of the water flow.
2. Dig out a sufficient size trench to take the toe along the front of the foundation. The toe should be installed first; mass concrete should be used to backfill in front and under the unit.
3. Lay a 100mm thick bed of semi dry concrete as a foundation to sit the headwall level, or with a slight fall (1:50) from pipe to spill mouth.
4. Using appropriate lifting clutches (available from Althon LTD) in the anchor positions on the wing walls lift the unit and carefully manoeuvre into position on prepared foundation.
5. Mass concrete should be used to backfill in front and under the toe and well compacted impervious clay around the rest of the unit.
6. Position pipe in prepared trench and insert through backwall of headwall (flush if with flap valve or grating -50mm protrusion if not).
7. Fill void around pipe with a good quality sand cement mortar.
8. Once satisfied with the positioning of the pipe, backfill in accordance with Engineers instructions.