

ALTHON MEARIN GRP CHANNEL Plus 300 and Expert 300

Datasheet

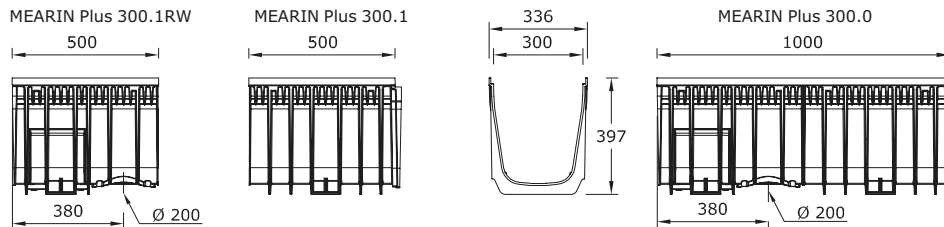

Material characteristics

Channel units and siltbox

- SMC (Sheet moulded compound)
fibre glass reinforced polyester unsaturated,
mineral fillers, additives
- Traction resistance 65 N/mm² (ISO 527)
- Flexion resistance 120 N/mm² (ISO 14125)
- Flexural modulus of elasticity 10000 N/mm² (ISO 14125)
- Longitudinally stretching coefficient 1,5-2,0 x 10⁻⁵ 1/K
- Constant heat 100°C permanent load, up to
200°C short-term
- Constant frost - 35°C
- Water absorption < 0,1% (ISO R178)
- Material structure capillary free

Edge protection

- **ALTHON MEARIN Plus**
fibre glass reinforced polyester
- **ALTHON MEARIN Expert**
Steel, continuously galvanised,
zinc thickness 18µ

Channel grating covers

- Hot-galvanized steel,
Zinc thickness 75 µ
- Cast iron: GGG (Sphäro)

Description and dimensions

- Fibre glass reinforced drainage channels with integrated channel groove
- With and without edge protection, galvanized steel
- Connection facility for outlet Ø 200mm, for vertical, sideways and horizontal connection
- Discharge capacity on cross sectional area 50 l/s
- Interlocking joint system for channel connection
- Channel connection facility sideways for T, corner and cross connections
- Half meter pieces for change at channel run
- Suitable for fitting MEARIN Plus and Expert 300 channel grating cover with STARFIX screwless grate safeguard

- Nominal size: 300 mm
- Fall available: no fall
- Load classifications: A15 to E600 according to EN1433
- CE compliant
- Total height: 397 mm
- Total width: ALTHON MEARIN Plus 300: 336 mm, MEARIN Expert 300: 332 mm
- Total length: 500 mm und 1000 mm
- Channel unit weight: MEARIN Plus 300: 11,80 kg / MEARIN Expert 300: 13,72 kg

ALTHON MEARIN Plus and Expert 300 2- or 3-parts polymer concrete gully

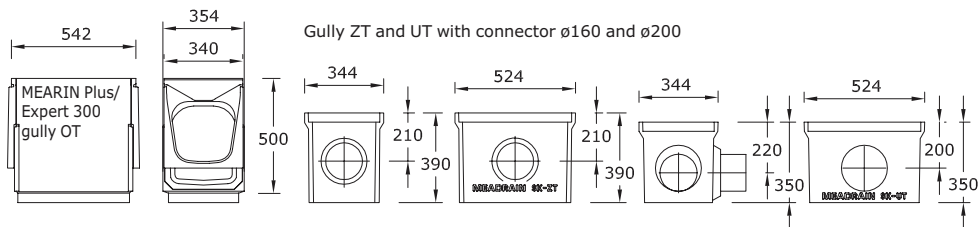

Description and dimensions gully

- Fitting MEARIN Plus 300 and MEARIN Expert 300 drainage channel
 - With edge protection, cast GG
 - In 2 sediment bucket variations, galvanized steel -
"short" for gully-top+bottom-combination;
"long" for gully-top+middle+bottom-combination;
 - Connection facility for ø160mm and ø200mm pipe
 - Interlocking joint system for channel connection
 - Suitable for fitting MEADRAIN-Top 3000 channel grating cover with PROFIX screwless gratesafeguard
- Nominal size: 300 mm
 - Load classifications: A15 to F900 according to EN1433
 - CE compliant
 - Total height: SK-OT+UT: 750 mm / SKOT+ZT+UT: 1100 mm
 - Total width: 354 mm (340 mm upper edge)
 - Total length: 542 mm
 - Weight: SK-OT: 39,10kg; SK-ZT: 22,00kg; SK-UT short: 24,00kg; SK-UT long: 33,60kg

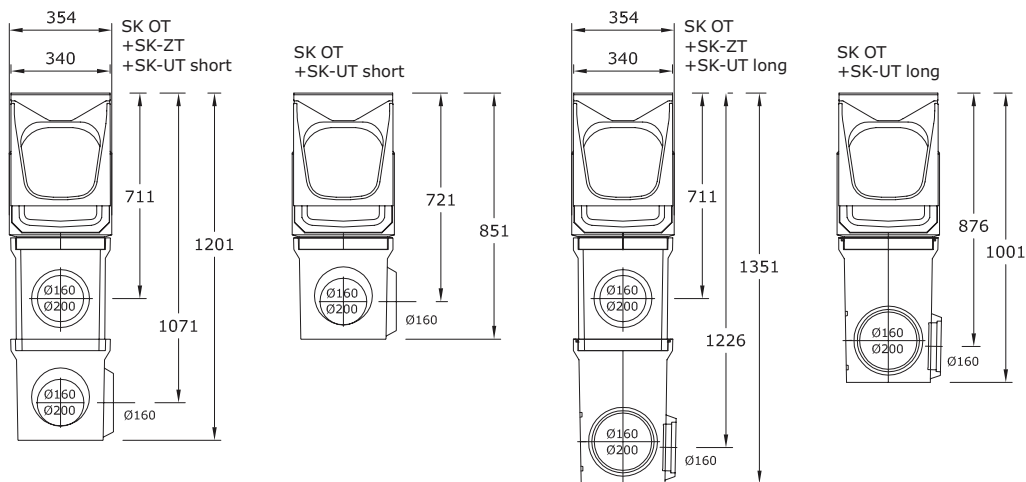

ALTHON MEARIN Plus and Expert 300 accessory

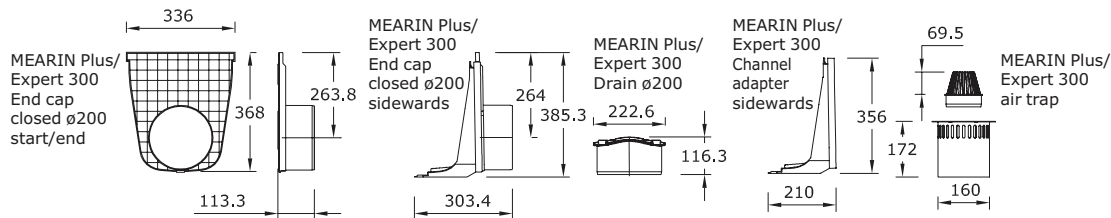

Description and dimensions accessory

- Fitting MEARIN Plus 300 and MEARIN Expert 300 drainage channel
- End Cap for Channel start and -end with connection facility \varnothing 200mm pipe
- End cap sideways seitlich for connection facility \varnothing 200mm pipe, 90° to channel run
- Adapter for connecting channel unit sideways, 90° to channel run
- Vertical outlet connection, for connection facility \varnothing 200mm pipe
- Roddable foul air trap mit dirt sieve and dirt trap, applicable for subsequent installation in vertical outlet connection
- Material polypropylene and galvanized steel
- All connectors fitted with channel groove according to EN1433

ALTHON MEARIN Plus and Expert 300 channel grating cover

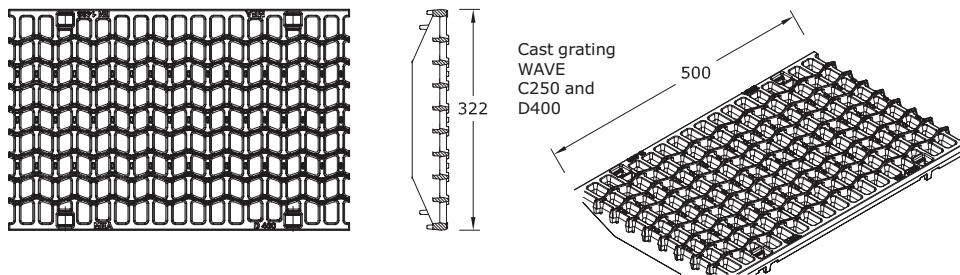

Description and dimensions

- Fitting MEARIN Plus 300 and MEARIN Expert 300 drainage channel
- With quick release fastener STARFIX
- Material Cast GGG50 and hot-galvanized steel, 75 μ
- Load classifications: C250, D400, and E600 according to EN1433

Description	Class mm	Length mm	Total width incl. grating mm	Insertion height mm	Weight kg	inflow cross section cm ²
MEARIN Plus/Expert 300 mesh grating, MW20/30	C250	1000	322	20	32,80	2265
MEARIN Plus/Expert 300 mesh grating, MW20/30	C250	500	322	20	16,20	2220
MEARIN Plus/Expert 300 cast grating WAVE	C250	500	322	20	15,50	1780
MEARIN Plus/Expert 300 cast grating WAVE	D400	500	322	20	19,00	1780
MEARIN Plus/Expert 300 cast grating WAVE	E600	500	322	20	22,00	1780
MEARIN Plus/Expert 300, solid cover closed	E600	500	322	20	20,60	–

ALTHON MEARIN Plus and Expert 300 System view



MEARIN® Expert. Solid grounded 4mm galvanized steel edge protection meets heavy duty demands

Innovative STARFIX grate fail-safe system:
Easy attaching and detaching of galvanized steel and cast grates - screwless, secure, fast

Complete, sealable GFK-channel unit system with accessory for standardised application:
EN 1433 compliant, CE compliant

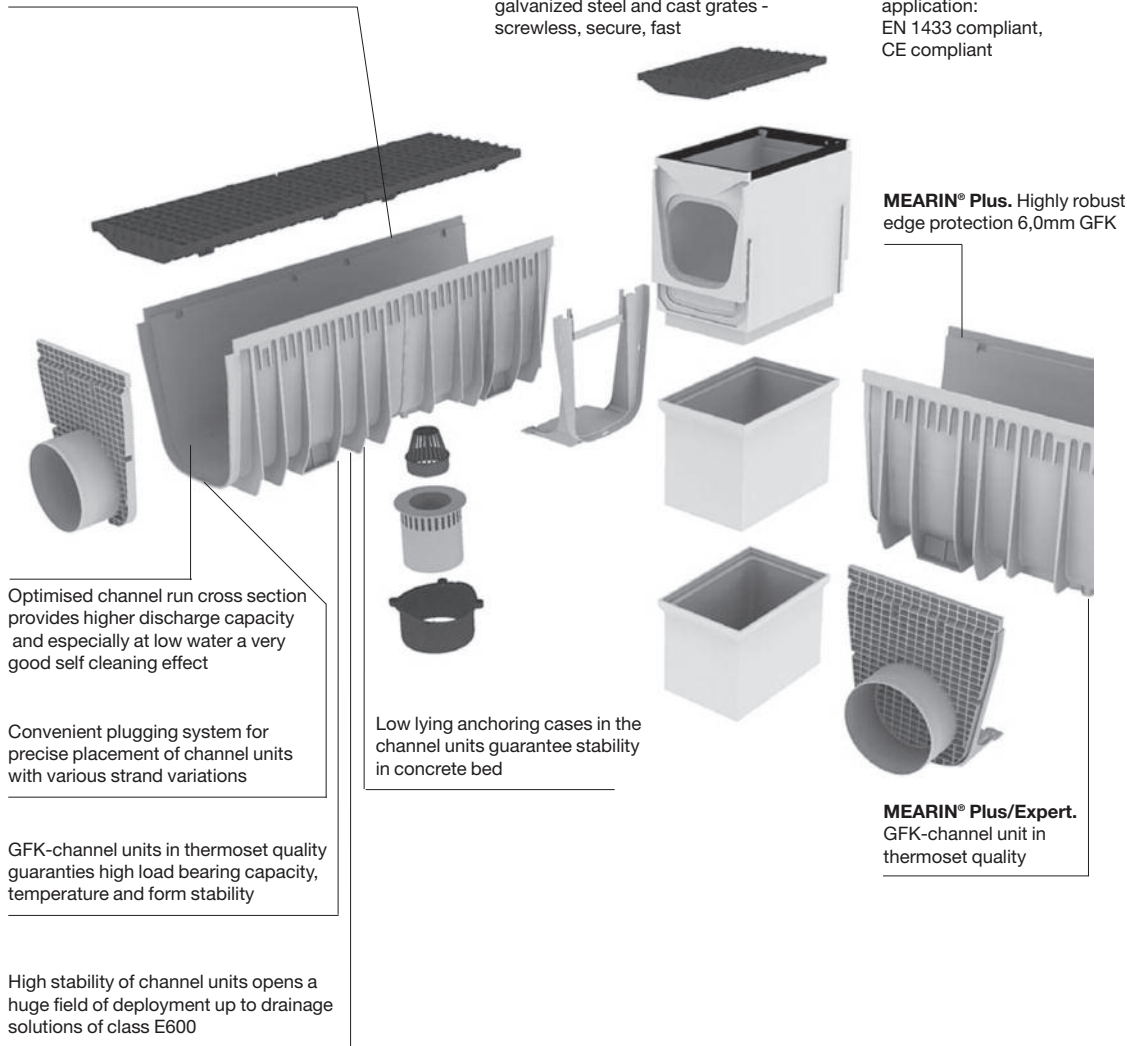

Optimised channel run cross section provides higher discharge capacity and especially at low water a very good self cleaning effect

Convenient plugging system for precise placement of channel units with various strand variations

GFK-channel units in thermoset quality guaranties high load bearing capacity, temperature and form stability

High stability of channel units opens a huge field of deployment up to drainage solutions of class E600

Low lying anchoring cases in the channel units guarantee stability in concrete bed

MEARIN® Plus. Highly robust edge protection 6,0mm GFK

MEARIN® Plus/Expert. GFK-channel unit in thermoset quality