

CSP27 Headwall Range

Max Internal Opening 2650 x 1750mm
1300mm - 2350mm Backwall Height

300 and 500mm Thick Toe

The Althon Culvert Headwall Range CSP27 will accommodate box culverts with a maximum internal dimension of 2650mm wide x 1750mm high. Available with four standard backwall heights 1300mm, 1650mm, 2000mm and 2350mm. CSP27 precast headwall units can be factory fitted with a range of accessories such as flap valves, penstocks, Kee Klamp® handrails and a selection of gratings depending on the application.

Our CSP Culvert Headwall Range is available with toe extensions either 300 or 500mm thick with depths ranging from 400 to 1000mm.

Optional Kee Klamp handrail and toe



CSP27A 1300mm Backwall

CSP27B 1650mm Backwall

CSP27C 2000mm Backwall

CSP27D 2350mm Backwall

CSP27E 1300mm Backwall

CSP27F 1650mm Backwall

CSP27G 1650mm Backwall



CSP27H 2000mm Backwall

CSP27I 2000mm Backwall

CSP27J 2000mm Backwall

CSP27K 2350mm Backwall

CSP27L 2350mm Backwall

CSP27M 2350mm Backwall

CSP27N 2350mm Backwall

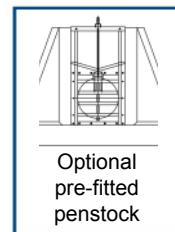
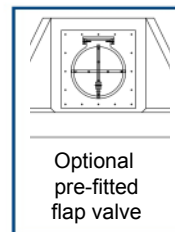
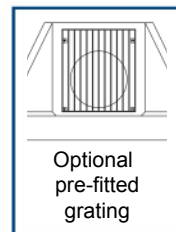
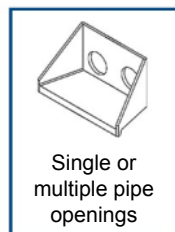
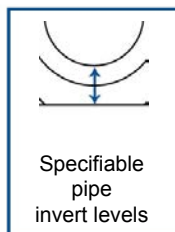
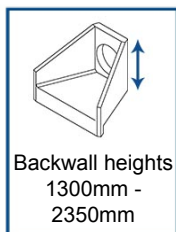
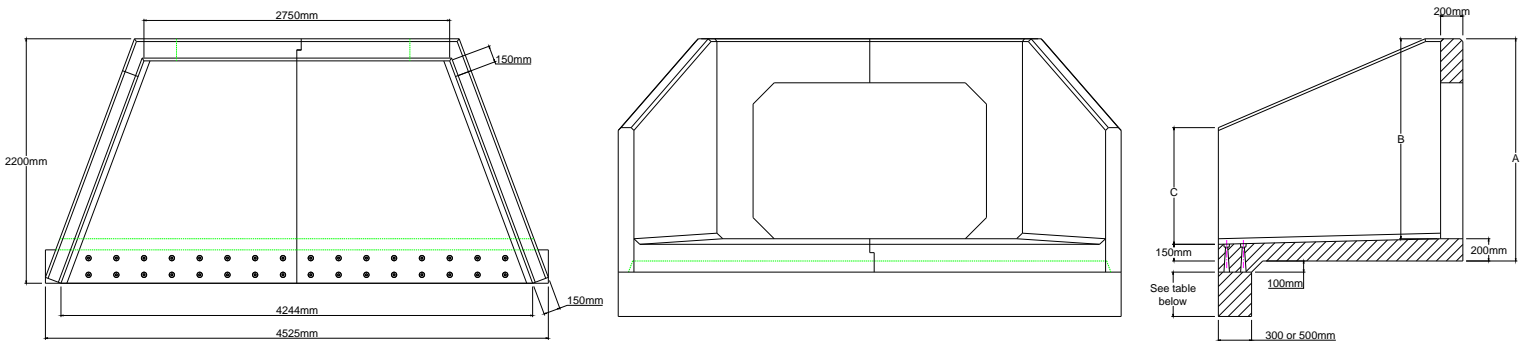

CSP27 Headwall Range

Max Internal Opening 2650 x 1750mm
1300mm - 2350mm Backwall Height

300mm Thick Toe

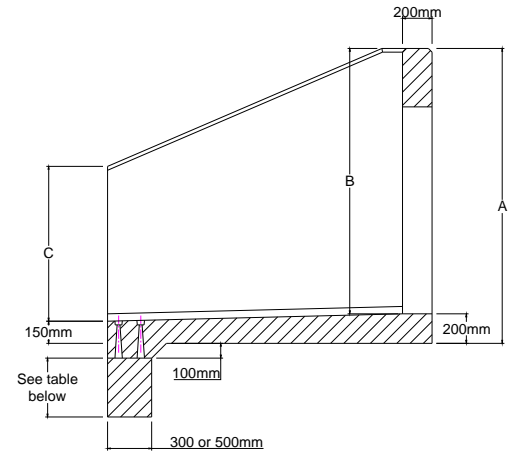

Headwall Ref	Back Wall Height A	Back Wall Height B	Front Wall Height C	Wing Wall Profile	Weight	Weight with Toe			Max Internal PCC Box Culvert Width x Height
						400mm	650mm	950mm	
	mm	mm	mm		kg	kg	kg	kg	mm
CSP27A	1300	1100	350	1:2.3	6720	8030	8850	9835	2650 x 700mm
CSP27B	1650	1450	350	1:1.6	7345	8655	9475	10460	2650 x 1050mm
CSP27C	2000	1800	350	1:1.24	8120	9430	10250	11235	2650 x 1400mm
CSP27D	2350	2150	350	1:1	8900	10210	11030	12015	2650 x 1750mm
CSP27E	1300	1100	1150	Horizontal	7120	8430	9250	10235	2650 x 700mm
CSP27F	1650	1450	700	1:2.3	7585	8895	9715	10700	2650 x 1050mm
CSP27G	1650	1450	1500	Horizontal	8155	9465	10285	11270	2650 x 1050mm
CSP27H	2000	1800	700	1:1.6	8370	9680	10500	11485	2650 x 1400mm
CSP27I	2000	1800	1050	1:2.3	8620	9930	10750	11735	2650 x 1400mm
CSP27J	2000	1800	1850	Horizontal	9190	10500	11320	12305	2650 x 1400mm
CSP27K	2350	2150	700	1:2.24	9150	10460	11280	12265	2650 x 1750mm
CSP27L	2350	2150	1050	1:1.6	9400	10710	11530	13825	2650 x 1750mm
CSP27M	2350	2150	1400	1:2.3	9650	10960	13365	14075	2650 x 1750mm
CSP27N	2350	2150	2200	Horizontal	10225	11535	12355	13340	2650 x 1750mm

500mm Thick Toe

Headwall Ref	Back Wall Height A	Back Wall Height B	Front Wall Height C	Wing Wall Profile	Weight	Weight with Toe			Max Internal PCC Box Culvert Width x Height
						500mm	750mm	1000mm	
	mm	mm	mm		kg	kg	kg	kg	mm
CSP27A	1300	1100	350	1:2.3	6720	9070	10435	11800	2650 x 700mm
CSP27B	1650	1450	350	1:1.6	7345	9695	11060	12425	2650 x 1050mm
CSP27C	2000	1800	350	1:1.24	8120	10470	11835	13200	2650 x 1400mm
CSP27D	2350	2150	350	1:1	8900	11250	12615	13980	2650 x 1750mm
CSP27E	1300	1100	1150	Horizontal	7120	9470	10835	12200	2650 x 700mm
CSP27F	1650	1450	700	1:2.3	7585	9935	11300	12665	2650 x 1050mm
CSP27G	1650	1450	1500	Horizontal	8155	10505	11870	13235	2650 x 1050mm
CSP27H	2000	1800	700	1:1.6	8370	10720	12085	13450	2650 x 1400mm
CSP27I	2000	1800	1050	1:2.3	8620	10970	12335	13700	2650 x 1400mm
CSP27J	2000	1800	1850	Horizontal	9190	11540	12905	14270	2650 x 1400mm
CSP27K	2350	2150	700	1:2.24	9150	11500	12865	14230	2650 x 1750mm
CSP27L	2350	2150	1050	1:1.6	9400	11750	13115	14480	2650 x 1750mm
CSP27M	2350	2150	1400	1:2.3	9650	12000	13365	14730	2650 x 1750mm
CSP27N	2350	2150	2200	Horizontal	10225	12575	13940	15305	2650 x 1750mm

Installation Guidelines

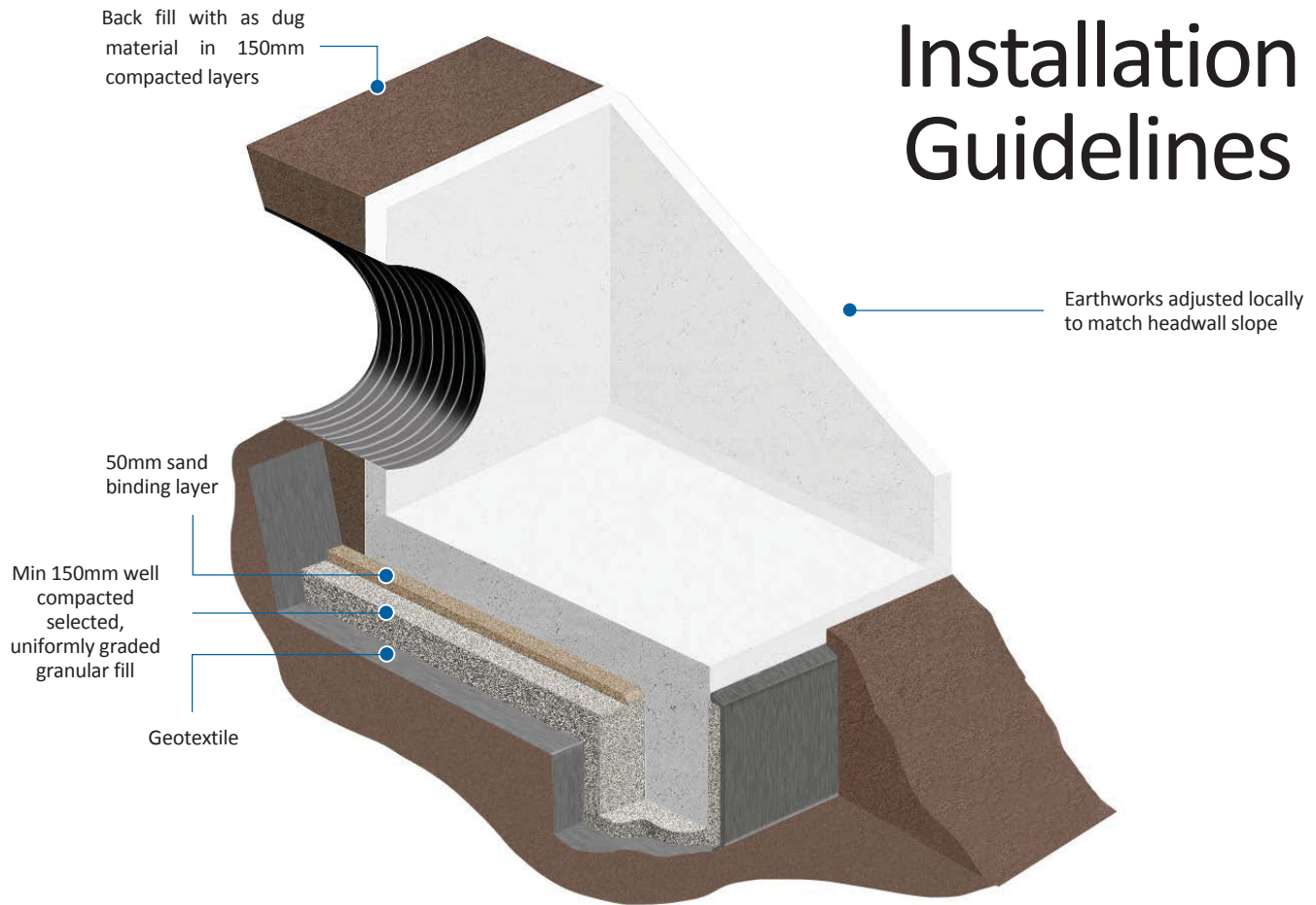

- 1 Ensure that first or last spigot/butt or socket/butt pipe that is to be fitted to the Headwall is in position and free from backfill.
- 2 Dig out the bank of the watercourse to take the size of the headwall making sure that the Headwall will not protrude into the path of the water flow. The angle of the excavation to the rear of the Headwall should be roughly the same as the existing bank profile.
- 3 Dig out sufficient size trench to take the toe along the front of the foundation.
- 4 Line toe foundation with Geotextile then place selected, uniformly graded granular fill in the base and compact well. Lift Toe into position and level then fill around the toe with selected, uniformly graded granular fill and compact well. Insert supplied threaded rod into the sockets cast into the top of the toe.
- 5 Line the base of the rest of excavation with Geotextile then place a minimum bed of 150mm Class 6A or 6K* Selected Well Graded Granular Material on the base & compact well, especially around the back of the toe, then a 50mm topping of fine material (Class 6L*) to ensure units are level and stable. Lift Headwall into position, over the end of the pipe & locate over threaded rod protruding from the toe and level. Place washer over threaded rod (SFA10 8 No) in recess in Headwall apron and tighten nut. Fill recess with high strength non-shrink grout.
- 6 The pipe should be flush with the front of the back wall if fitting grating or flap valve, or protruding by 50mm if not.
- 7 Shim the pipe until it is central within the opening then fill void with sand cement mortar or high strength non-shrink grout.
- 8 If flap valve or grating is supplied, this will need to be removed before the pipe is inserted and sealed into place. Then reinstall using stainless steel fixing bolts into cast in sockets. (When bolting flap valves against headwall, use a good quality sealant but do not over tighten bolts or distortion may occur resulting in the valve not seating correctly.
- 9 Backfill pipe section first then backfill all around Headwall with as dug material. Make good at front of toe with as dug material ensuring river bank is returned to its original profile. It may be necessary to provide protection in front of the toe, please refer to engineers' recommendation.

*Manual of Contract Documents for Highway Works: Volume 1 (MCHW1), Specification for Highway Works, Series 600 (Nov 09)



Rapid-Lift Lifting Anchors

All Althon CSP Headwalls and Toes are fitted with Rapid-Lift lifting anchors. The Althon Rapid-Lift system allows the CSP Headwalls & Toes to be offloaded, transported and located in their final position without the need for any specialised lifting equipment. Standard lifting hooks and chains can be used with the three lifting points (two lifting points on Toes). The minimum chain leg length for all units is 1500mm.

Althon Precast Concrete CSP Headwall Safety Sheet

Althon Limited manufacture pre-cast concrete CSP Headwalls using :-

6 - 14mm aggregate · 0/4mm Sharp sand · Portland cement BS EN 197-1- Cem 1 52.5 · Cryso Fluid Premia 205 Varit Superplasticiser

When units have been manufactured and cured they are in a chemically inert state. But the following information should be considered.

- It is advisable to wear toe cap safety footwear when handling any concrete products. Please refer to your company Safety Policy for specific details on manual handling.
- When cutting with masonry grinding discs or drilling with masonry drill bits it is necessary to wear eye protection and a dust mask. It is also recommended to wear ear protection during either of these two processes.
- Due to some units having sharp edges it is advisable to wear protective gloves when handling Althon products.
- When fitting or removing some of the larger accessories it is necessary to use a mechanical system to prevent risk of back injury.

Maintenance of CSP Headwalls

With respect to the maintenance of any exposed surfaces of concrete components, only routine (Annual) cleaning may be necessary with a Power Washer and possibly some mild detergent to any exposed surfaces to maintain appearance; however all sites are unique and environmental impact of cleaning should be taken into account. Where cleaning is required and environmental conditions prevent mild detergent, using clean water and a power washer/stiff brush should suffice. Concrete units are often expected to “weather” and some coverage will help them to blend into their environment.

If damage to the structure of any pre-cast concrete components occurs we recommend their replacement not repair. If there is minor damage to corners during their normal life by grass cutting equipment etc. then repair with an epoxy compound such as ‘Mason Mate 0868PR380 Polyester Resin’.

To dispose of any Pre-Cast concrete components the preferred method is to recycle the material by crushing and grading, but if the quantity is too small to be cost effective then disposal in conventional landfill is acceptable as all the concrete components are inert with regard to having any environmental impact.

Maintenance of Galvanised Grates & Handrails.

Annual/bi-annual visual checks are basic recommendations. If gratings are in a water course subject to a higher level of debris/weed, then more regular checks may be required. Clearing of debris/weeds from the grate will ensure no disruption to the flow, or backing up of the water course. Handrails should also only require a visual inspection – annually or at the same time as the headwall & grates.