

## Check-Flex® G5 Inline Check Valves Installation, Operation and Maintenance Manual

---



### Check-Flex® G5 Inline Check Valve

Tough Reinforced Vulcanised Construction

The Check-Flex® G5 inline valve is the latest generation of inline check valve and offers a smooth upstream profile with a full 150° roof connection. The G5 is built from radial layers of fabric reinforced rubber, which are hot vulcanised into a single piece valve. The unique fold away design of the inner sleeve delivers near full port flow and fast drainage.

The materials used are rated for severe service including unscreened highway run off and even steam detergent wash down areas in food plants. The fibre reinforcement prevents tearing from glass shards, grit and debris. The neoprene will flex without fatigue in the same way as a tyre flexes each rotation.

The one piece design allows the valve to flex without the point stress of older three piece assembled design. The valve combines a Sealing Gasket, Moving Flap and Container into a single integrated product. There is no hinge mechanism to be maintained.

Sealing directly to the pipe means no work to the existing wall opening or benching. Angled pipe openings, ring manholes and damaged pipe ends, need no extra work as the installer can recess the valve into these pipes to make the valve-to-pipe seal.

The tough one piece reinforced construction offers long life in all drainage locations, including coastal and saltwater areas without periodic maintenance.

The low headloss and fast installation with hand tools means these valves are a simple addition to any property to protect against public sewer surcharging, flooding and odours. These valves are often fitted to car park drains in retail and commercial sites to prevent odours and flooding.

Flanged models are available and these are ideal for connecting to mating flanges on process tanks and pipework. In civil headwalls, the flange bolt circle may meet the end of the pipe and compromise the connection. Insert Direct to Pipe models have the same pressure rating and are the most common connection choice.

The Check-Flex® G5 requires no external power and is silent in operation. The valve has a virtually instant response to backflow and is suitable for odour control applications.

***Important:*** Each Check-Flex® rubber check valve installation can be considered a major pipe installation and the same safety requirements as used in pipe contracting installations should be implemented. Each Check-Flex® rubber check valve regardless of size should be installed in the same manner.

---

# Check-Flex® G5 Inline Check Valves Installation, Operation and Maintenance Manual

## Check-Flex® G5 Inline Check Valve

Tough Reinforced Vulcanised Construction

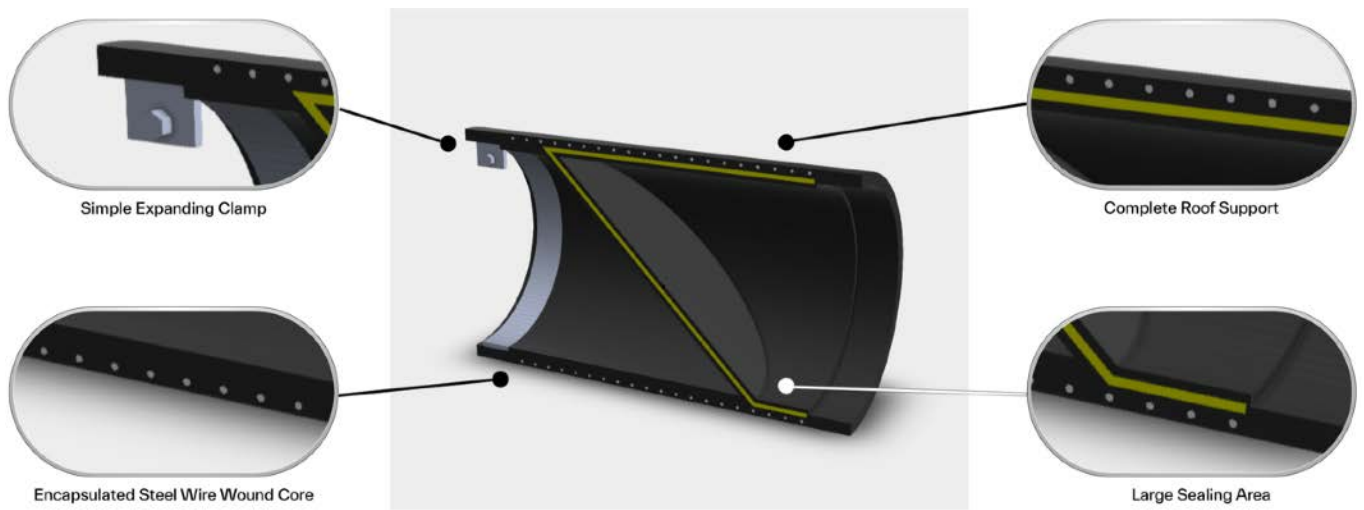

**Simple installation!** insert into pipe and clamp in place, no modification to pipe or structure

# Check-Flex® G5 Inline Check Valves Installation, Operation and Maintenance Manual

## 1. Mounting Options

### IDP model

Insert Direct to Pipe with Universal Clamp for simple and secure installation

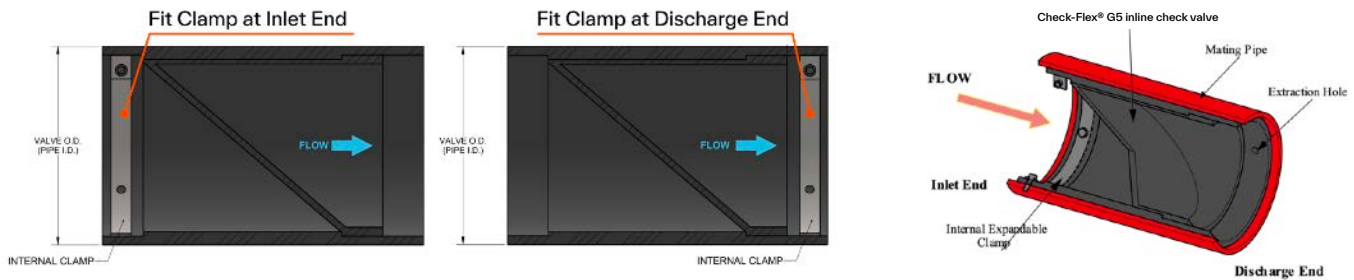

The expanding c-clamp of the Check-Flex® G5 inline valve can be used in either the Inlet End or the Discharge End of the valve. Simply insert the clamp and expand to create a watertight seal to the pipe wall.

Sealing directly to the pipe means no work to the existing wall opening or benching. Angled pipe openings, ring manholes and damaged pipe ends need no extra work as the installer can recess the valve into these pipes to make the valve-to-pipe seal.

The expanding c-clamp uses the valve wall as a gasket to seal against the bore of the pipe.

The valve-to-pipe sealing method works on drainage pipes with slight out of roundness and surface imperfections.

### IE or DE Flanged model

Inlet End and Discharge End models

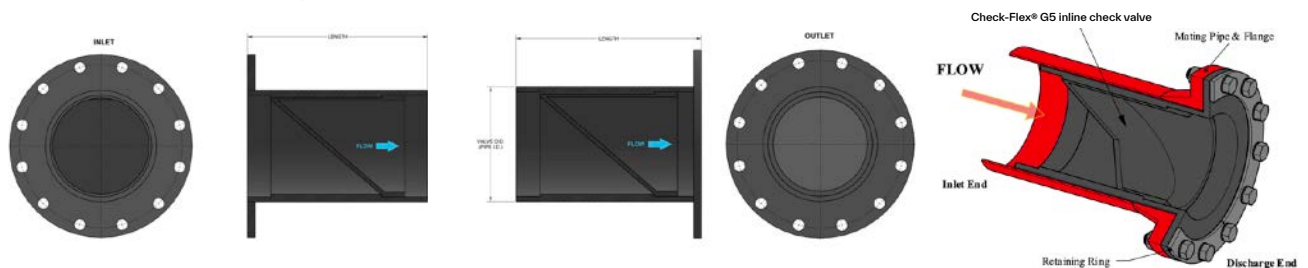

Flanged models connect to mating flanges on existing pipes. There is no difference in the pressure rating of the flanged models compared to the IDP models.

In civil headwalls, the bolt circle may meet the end of PCC pipes and this should be checked to ensure sufficient embedment clearance for anchors.

The thick [27-40mm] rubber flange is the sealing. There is a retaining plate encapsulated within the rubber. Any flange drill pattern is available to order.

# Check-Flex® G5 Inline Check Valves Installation, Operation and Maintenance Manual



valve sizes  $\leq 450$ mm have 1 expanding clamp

valve sizes  $\geq 500$ mm have 2 or 3 clamps

## 2. Shipping

The Check-Flex® G5 inline valve offers the versatility of being installed from the inlet end or discharge end, it has two cuff ends and one clamp set, the fixing clamps are put in the end the valve is fitted from, so gives the option for installing at many different locations i.e. chamber inlet or chamber outlet or at the end of an outfall etc. no modification is required to the structure or pipework.

Once the installation orientation is determined on site the Check-Flex® G5 inline valve will be clamped from the upstream or downstream side.

Check-Flex® G5 inline valve sizes  $\leq 450$ mm diameter have one expanding clamp, valve sizes  $\geq 500$ mm have two or three clamps that are installed in the same cuff end of the valve and offset from each other with the turnbuckles spaced evenly. During shipping the clamps may be located in each end of the valve, once the installation orientation is determined the clamps will be located in the one cuff end.



## 3. Handling

Care should be taken when handling the Check-Flex® G5 inline valve big or small, to reduce the possibility of damaging the check valve during installation.

Do not use sharp instruments when unpacking as it may damage the rubber valve.

For large size check valve sizes, special care should be taken in loading, hoisting, and lowering; being careful not to hit adjacent equipment, forklift tines, crane cables, etc.

Large Check-Flex® valves can be lifted with a sling/supports around the O.D. at each side of the valve to ease the installation procedure. Do not put an object through the valve in order to lift it.

Note: We will not be responsible or liable for damage to the rubber check valve, adjacent equipment, or injury to personnel if these steps are not taken.

# Check-Flex® G5 Inline Check Valves Installation, Operation and Maintenance Manual

## 4. Inspection of the received Check-Flex®

Check-Flex® valves are fully inspected at the factory and are carefully packaged to arrive at the job site ready for installation. Upon receipt of the check valve(s), inspect for any damage that may have occurred during transportation and immediately contact your transportation company to report any damage. Check the item(s) received against the packing slip to ensure that all items have been received.

Check-Flex® valves are clearly marked on the top showing valve serial number and size dimension, flow direction arrow and top marking. Valve label marking size should match the ordered valve size and site pipe I.D.



## 5. Pipe size measurement

The site pipe (I.D.) inside diameter should be checked on site prior to insertion.

The pipe I.D. should be round and a consistent diameter over the length of valve.

The pipe I.D. should be checked at a number of points around the circumference and over the length of the valve.

Where there is a tolerance +/- in the pipe I.D., the Check-Flex® should be ordered to the smallest pipe I.D. measurement, to allow ease of installation.



# Check-Flex® G5 Inline Check Valves Installation, Operation and Maintenance Manual

## 5.1 Tape and Adapters (Option)

Check-Flex® G5 valves can be used with tape or rubber adapters to seal to the pipe.

The purpose of additional tape or adapters is to ensure a water seal to the pipe. These can be useful for pipes that are not common sizes, or that are out of round. The valve is secured to the pipe by clamp pinning as usual.

Tape wrap is used for smaller valves to 400mm and adapters for larger valves. The adapters are fixed to the outside of the valve for ease of installation. The tape and adapters can be removed and cut to length on site.

Procedure: when the supplied valve outside diameter is too small to fit the site pipe inside diameter, rubber build out tape can be added to the clamp cuff end to match the actual site pipe ID.

Step.1 Measure the site pipe (ID) inside diameter

Step.2 Measure the valve (OD) outside diameter

Step.3 Apply the tape wrap around the valve cuff clamp end to match the site pipe ID

Step.4 Check the valve OD snugly fits within the pipe ID

Step.4 Install the valve as per normal instructions outlined in this manual, tightening the clamp secures the valve against the pipe compressing the rubber to the pipe ID, creating a seal and fix to the pipe.



G5 tape for small valve sizes <400mm

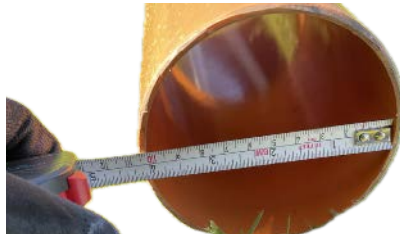

Measure the site pipe I.D.

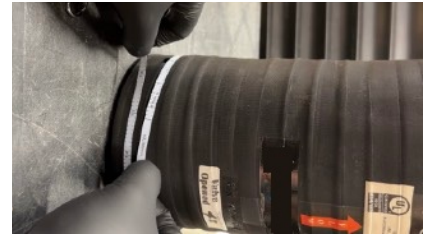

Measure the valve O.D.



Build out the valve O.D. to match the site pipe I.D.



Apply tape around the valve cuff clamp end



Check the valve O.D. snugly fits within the pipe I.D.



G5 rubber adapter for large sizes >400mm



G5 rubber adapter fixed to the valve cuff clamp end



Tightening the clamp compresses the rubber to the pipe

# Check-Flex® G5 Inline Check Valves Installation, Operation and Maintenance Manual

## 6. Site pipe inspection

Inspect the pipe inside diameter and the internal surface over the valve length to ensure that the pipe is undamaged and clean and free of all foreign matter before installation of the check valve, the pipe must be free of sharp edges which may damage the check valve during insertion.

For flanged connection option, inspect the mating flange/surface to ensure that it is undamaged and clean and free of all foreign matter before installation of the Check-Flex® valve

The Check-Flex® G5 inline check valve is supplied to fit the site pipe I.D., do not attempt to install a Check-Flex® in a smaller pipe I.D.



## 7. Installation Orientation

The Check-Flex® G5 inline check valve must be installed in a horizontal pipe and will be supplied with a “FLOW” direction arrow label and a “TOP” label to ensure proper installation orientation within the pipe. The Check-Flex® G5 inline check valve is inserted fully into the site pipe and finishes flush, so that no part of the valve extends beyond the end of the pipe, the valve should be fully support within the pipe over its full length.

NOTE: It is imperative to ensure the valve is installed at the 12:00 position.

Backflow leakage may occur if orientated out of plumb, the valves cone sealing area at 4:00 and 8:00 o'clock position would be subjected to uneven back pressures.



# Check-Flex® G5 Inline Check Valves

## Installation, Operation and Maintenance Manual

### 8. Fixing Clamps

Insert the expandable internal c-clamp(s) into the rubber check valve in either the inlet or discharge end depending on installation orientation and ensuring that the turnbuckle adjustable bolts are located at the top of the valve. When installing multiple internal expanding c-clamps ensure the clamps are evenly spaced/ rotated to provide even clamping pressure, as well as the internal expanding fasteners located in a position that minimises flow interference. For dry or hot installations, it is recommended to apply a layer of water based lubricant to the internal expanding clamp to assist in proper placement and sealing of the clamp.



Check-Flex® G5 inline valve sizes  $\leq 450$ mm diameter have one expanding clamp,  
Check-Flex® G5 inline valve sizes  $\geq 500$ mm have two or three clamps that are installed in the same cuff end

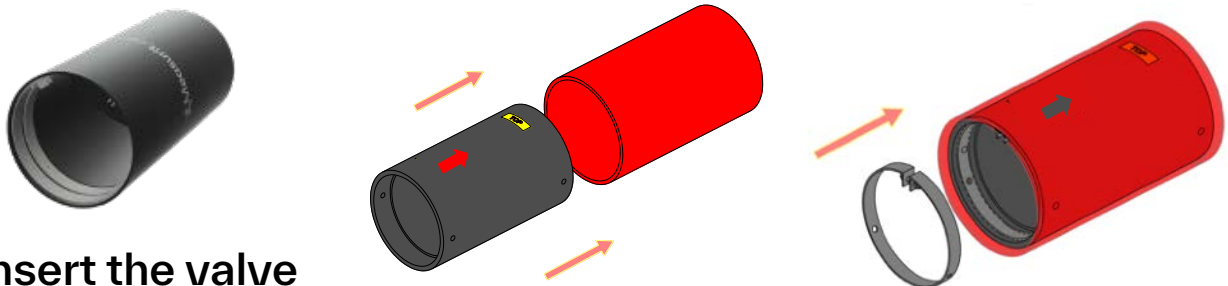

### 9. Insert the valve

Prior to insertion the outside of the valve body can be lubricated with a water-based lubricant to aid in installation. Check flow direction and orientation marks, the expanding c-clamps can be left slackened when inserting to allow ease of installation, if left expanded when fitting may hinder their insertion.

Insert the Check-Flex® G5 inline valve inside the site pipe and push in until fully inserted/flush with the end of the site pipe.



# Check-Flex® G5 Inline Check Valves Installation, Operation and Maintenance Manual

## 10. Insertion of Large & XL size valves

For Large & XL heavy sized Check-Flex® G5 inline valves, the shipping pallet or a heavy timber can be placed across the end of the valve to aid in pushing the valve fully into the pipe using a machine.

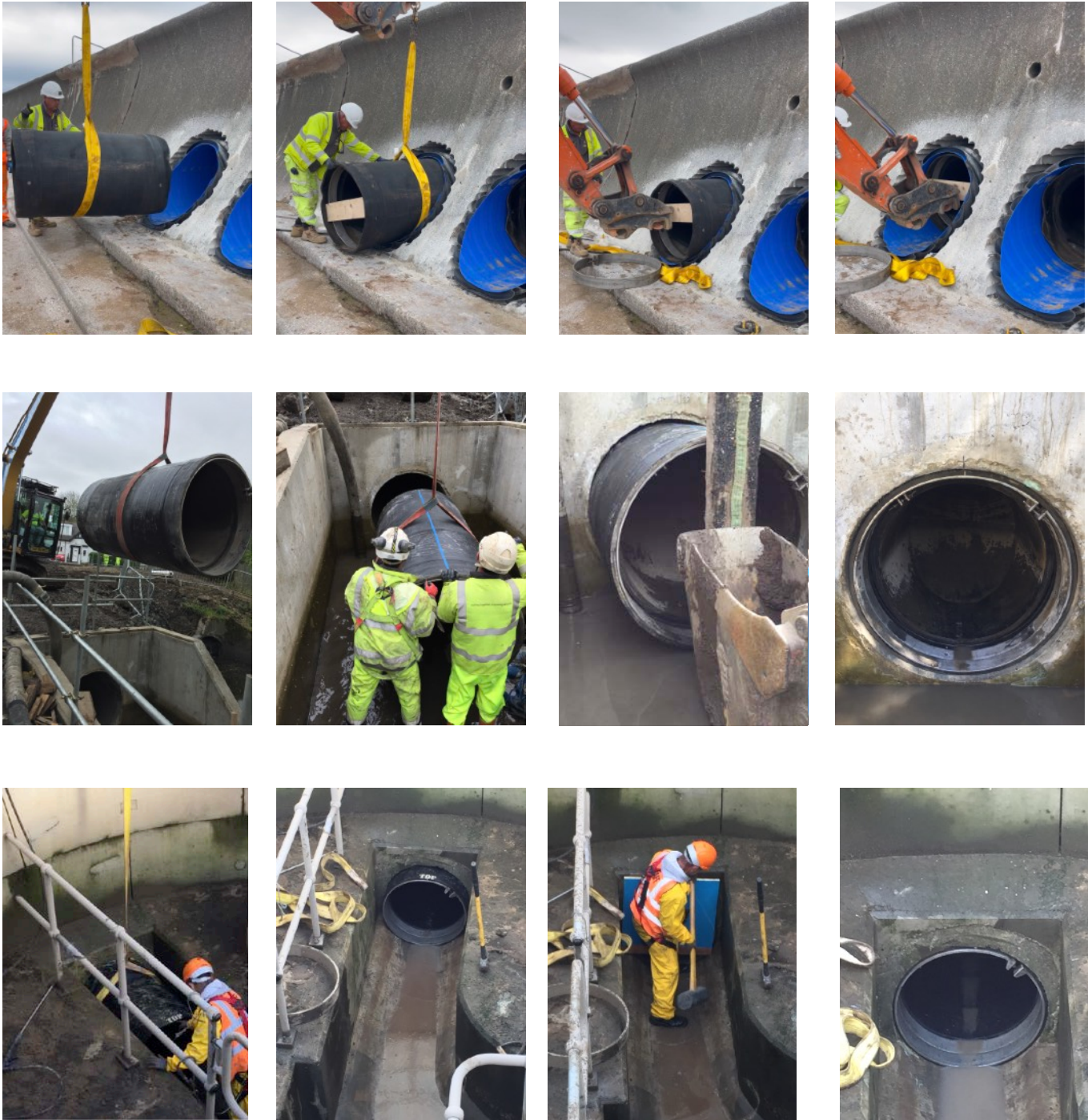

# Check-Flex® G5 Inline Check Valves

## Installation, Operation and Maintenance Manual

### 11. Expand Fixing Clamps

The Check-Flex® G5 Inline valves internal expanding clamps are tightened using a spanner fixing the valve in place. This type of check valve installation relies on external pressure of the internal expandable clamp to ensure that the valve seals against the pipe ID and does not move, care should be taken to ensure proper sealing.

Tighten the expandable internal c-clamp until the stainless-steel portion of the clamp has embedded itself into the rubber cuff of the valve. Tapping the clamp with a hammer will help the clamp expand against the friction. During shipping the c-clamp may become out of round, the clamp can be tapped back into shape using a lump/club hammer on the inner side of the clamp hitting in a circular motion around the clamp back into shape, to further embed the clamp into the rubber.

Re-tighten the clamp to ensure a proper seal. Once the clamp is properly sealed, tighten the lock nut on the internal expandable clamp.

Note: In large valve sizes where there are two clamps the clamp turnbuckles should be oriented 45° from the top centre plumb line, i.e 2 & 10 o'clock position, fitted in the same cuff end. For XL valve sizes 3/multiple clamps, ensure the clamps are evenly spaced/ rotated to provide even clamping pressure with the turnbuckle fasteners located in a position that minimises flow interference.

The expanding clamps have pre-drilled holes to allow the valve to be pinned to the pipe once the clamps are fully tightened out they should be pinned to the pipe.

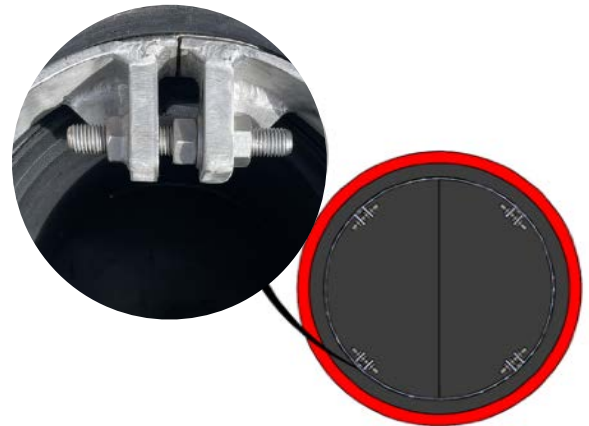
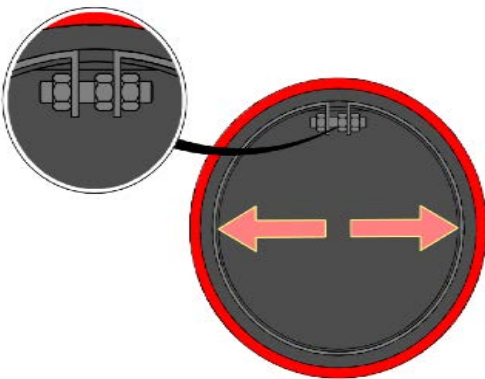

# Check-Flex® G5 Inline Check Valves Installation, Operation and Maintenance Manual

## 12. Anchor Bolts/Pins

After the Check-Flex® G5 Inline valve is installed, drill a hole/holes, depending on the valve size and number of clamps, through the cuff of the check valve and into the mating pipe using the center hole on the clamp as a guide. Insert a bolt, which will be sufficient in length to completely travel through the clamp, valve and mating pipe, ensuring that this bolt/pin will not fall out or be removed, to ensure the clamps do not slacken over their long lifespan, offering trouble free operation.



# Check-Flex® G5 Inline Check Valves Installation, Operation and Maintenance Manual

## 13. IE/DE Flanged model

The Check-Flex® G5 inline check valve must be installed in a horizontal pipe and will be supplied with a “FLOW” direction label and a “TOP” label to ensure proper installation orientation within the pipe. Insert the inline flanged check valve inside the existing pipe and push until flanged inlet/discharge end is flush with the end of the pipe. Note: Check-Flex® G5 inline check valve can be supplied with the integrated rubber flange on the inlet end or discharge end depending on the required site installation position and have the option to come with retaining backing rings or to have fully encapsulated retaining ring within the integral rubber flange.

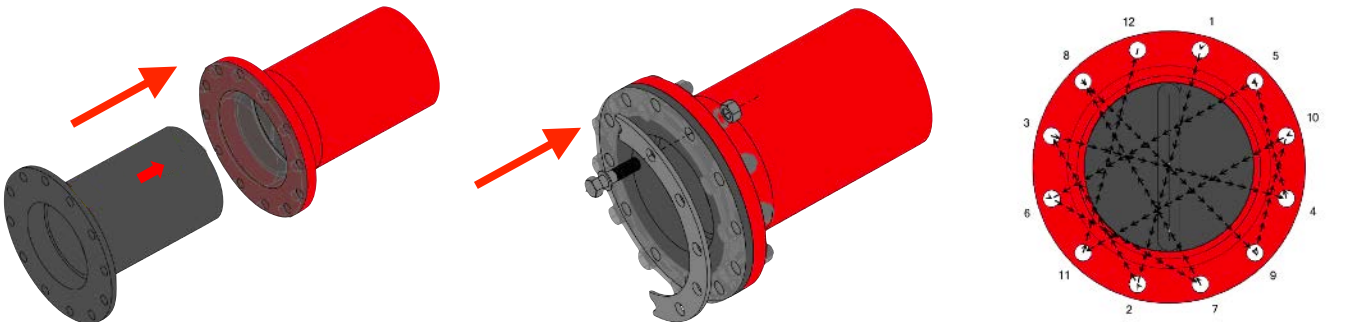

## 14. Retaining Ring & Bolt Torquing Installation

Attach and secure the retaining ring in place with the flange bolting hardware. Torquing of the bolts should be in steps gradually and as evenly as possible around the circumference of the flange. The bolts should be tightened in an alternating sequence similar to a star pattern shown in the above image and to within the proper torque range specified for the size of check valve to be installed. The flange bolting is not considered tight and “locked-on” until the edges of the check valve flange bulges out or extrudes slightly. Refer the below table on next page for the proper ranges of torque values as well as further examples of the proper patterns used for torquing the flange bolting. Note: Never tighten bolts on a flanged rubber check valve to the point where there is contact between the retaining ring and mating flange. This type of tightening will crush the integrated rubber flange of the check valve and cause a premature failure.

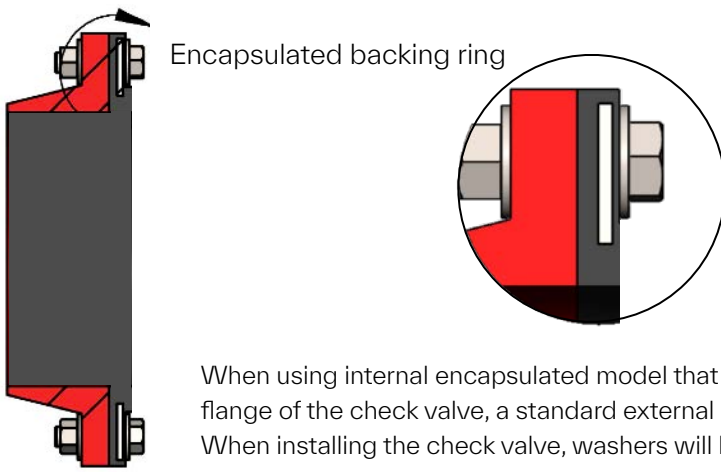

Encapsulated backing ring

When using internal encapsulated model that has a steel retaining ring embedded within the rubber flange of the check valve, a standard external retaining ring is not required. When installing the check valve, washers will be required on all fasteners to produce an adequate seal.

# Check-Flex® G5 Inline Check Valves Installation, Operation and Maintenance Manual

## 15. Bolt Torquing

### Torque Data

Check-Flex® Flange Torque (encapsulated ring)	
Size	Torque Values
75mm - 600mm	70 Nm
700mm - 2800mm	80 Nm

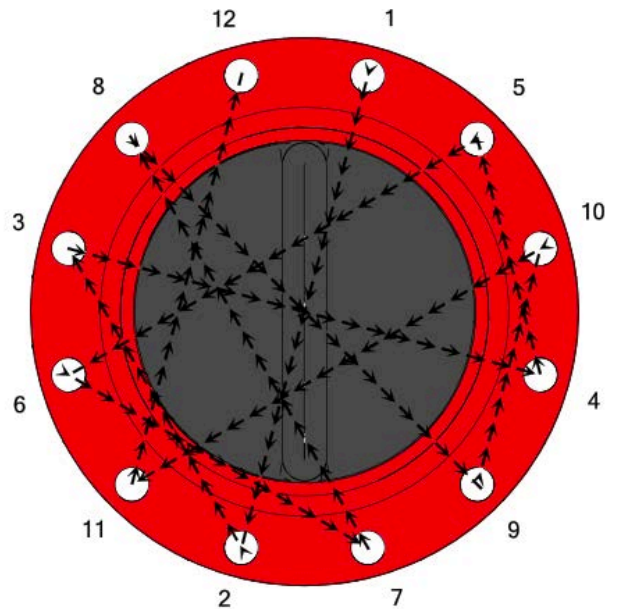
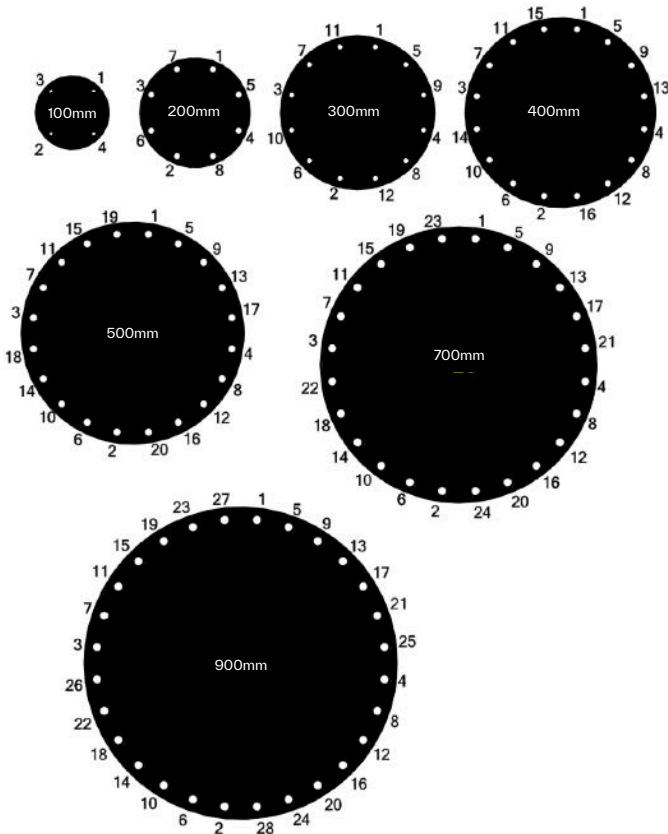
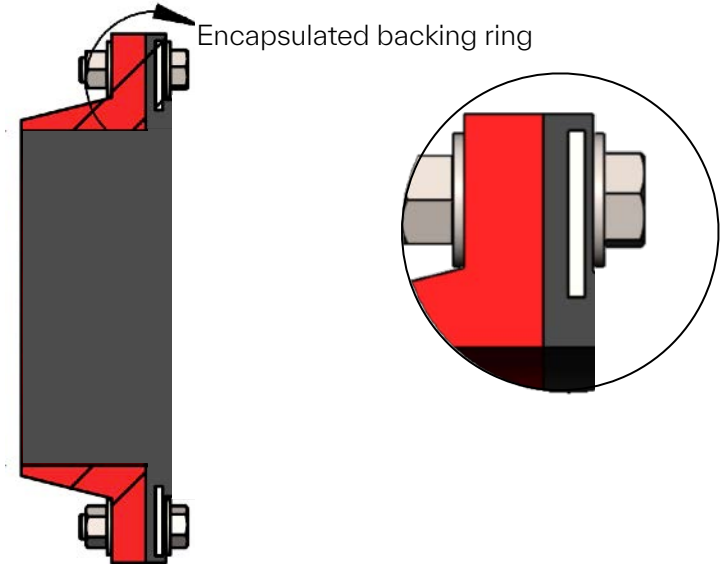

## Check-Flex® G5 Inline Check Valves Installation, Operation and Maintenance Manual

### 16. Extraction Method

Demonstration of Check-Flex® G5 inline check valve Extraction using cuff extraction holes.

If for any reason the valve needs to be removed from the line for access, it can be extracted using the extraction holes in the valve cuff.

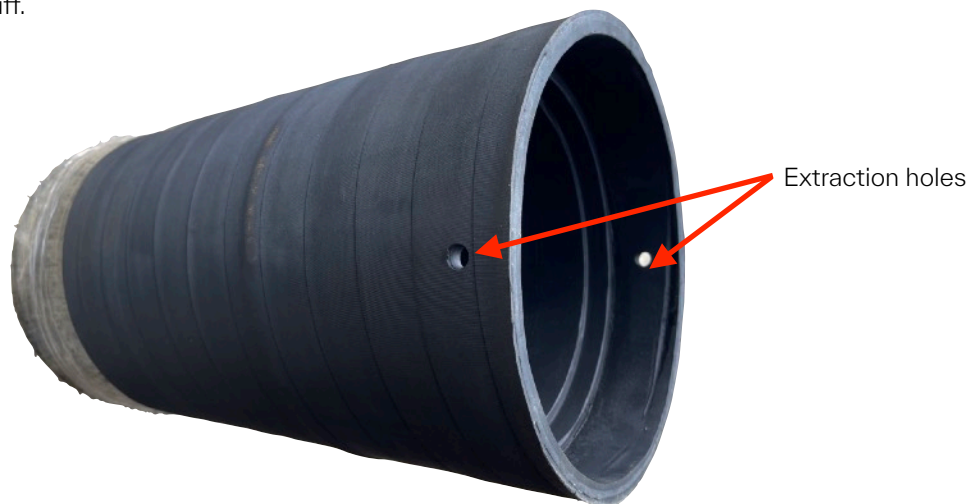

Remove the expanding fixing c-clamp from the end of the valve.

Using slings/chains, attach to the two extraction holes provided in the cuff (3 & 9 o'clock position), the valve can be pulled out using a machine where there is access or using a tirror winch, slowly apply force pulling the valve out off the line.

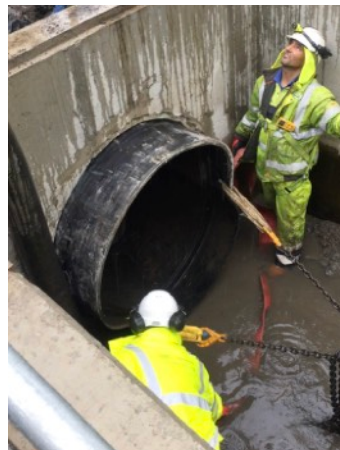

The same method can be used to pull the Check-Flex® G5 inline check valve into the pipe when installing via tirror winch. Where there is no machine access or space in an upstream chamber to drop the valve through an access hatch cover, the valve can be pulled into the line; attach slings to the extraction holes, using an anchor point and tirror, pull the valve into the pipe, ensure outside of valve body is lubricated to allow ease of insertion, remove the expanding clamp when pulling in and when in final position put the expanding clamp in the cuff and fix in place.

# Check-Flex® G5 Inline Check Valves Installation, Operation and Maintenance Manual

## 17. Storage

If the Check-Flex® valve is to be stored for a period of time prior to installation, the below guidelines will help to protect the valve and assure a trouble free installation:



### Inside

The ideal storage location for a Check-Flex® rubber check valve is in a warehouse setting with a relatively dry and cool location. Store the check valve in a vertical position on a pallet or platform.



Check-Flex® G5 Inline Check Valves will be stored upright on their end, XL sizes will be supported on a large skid

### Outside

If the Check-Flex® rubber check valve is to be stored outside, keep the check valve protected in a waterproof shipping pallet/crate the valve was delivered in until ready for installation. Keep the check valve protected from any external elements such as direct UV exposure or chemicals. Do not lay or stack other boxes on top of the check valve or check valve box.

# Check-Flex® G5 Inline Check Valves

## Installation, Operation and Maintenance Manual

### 18. Maintenance & Inspection

Check-Flex® check valves require little maintenance.

Periodic inspections can ensure that the Check-Flex® check valve will provide years of maintenance-free service. Check for any damage, wear or debris buildup. Ensure the bill section is free from any debris. The frequency of inspection should be determined by the local environment conditions and severity of the service where the valve operates.

Line pressure can flush the valve clean of debris in most cases, periodic inspections for trapped debris should be conducted.

Small valve sizes can be easily opened by hand, for large sizes the valve can be easily opened by inserting a feathered round ended pry bar into the bill of the valve to pry open to inspect for any debris that may be trapped.

Visual inspection:

- open/close the valve
- check for buildup of debris or damage
- check expanding c-clamp fixing turnbuckle bolts and pinning bolts for tension.

